



„Der Gute Geschmack ist die Fähigkeit, fortwährend der Übertreibung entgegenzuwirken.“

“Good taste is the ability to constantly resist exaggeration.”

« Le bon goût est l'art de ne jamais tomber dans l'excès »

Hugo von Hofmannsthal



CUBE | Auffallend Unauffällig | Conspicuously inconspicuous | D'une discrétion qui saute aux yeux

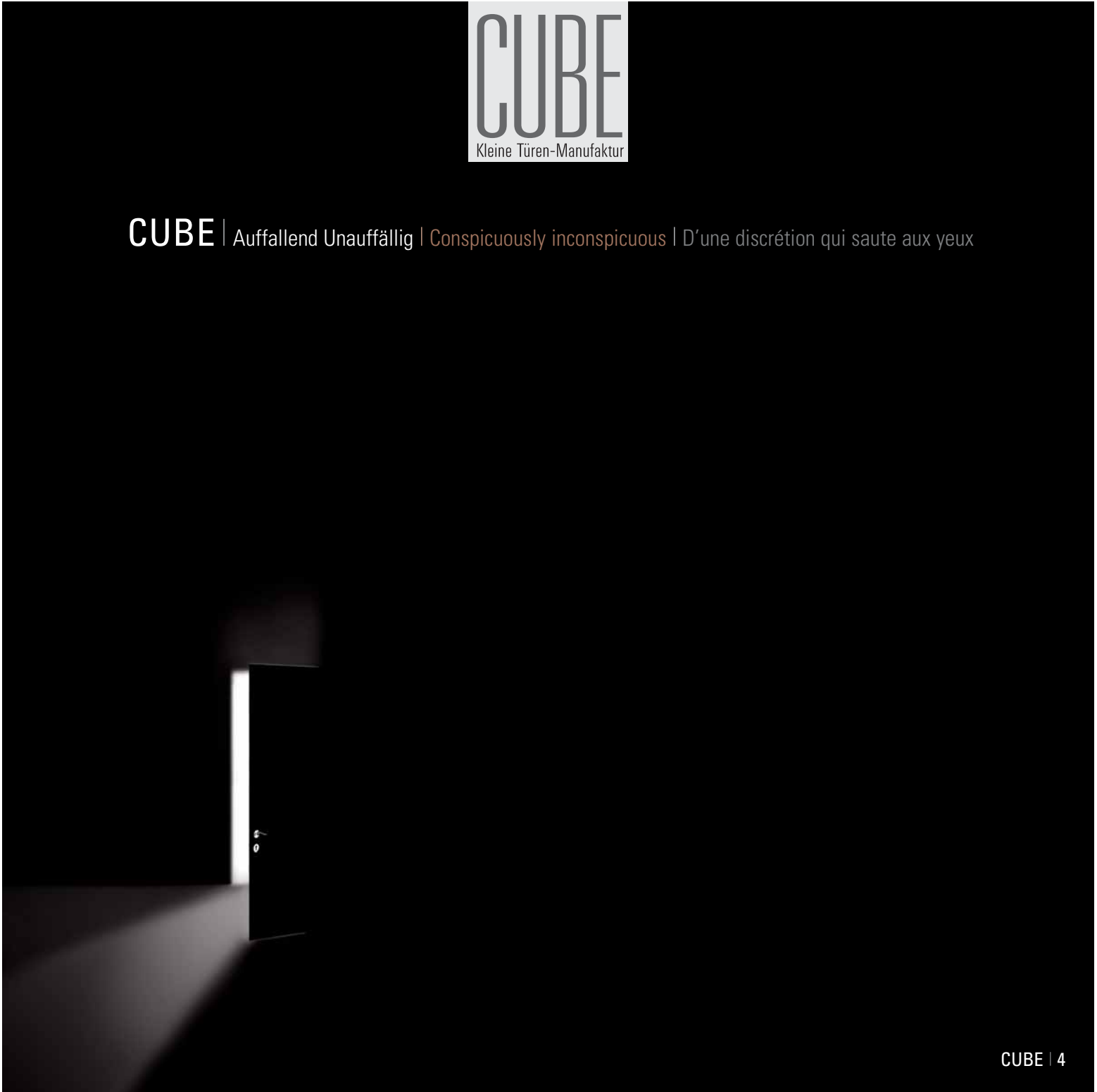





CUBE | ist ausgezeichnet

Seit 1955 markiert das Design-Zentrum international herausragendes Produktdesign mit dem begehrten **reddot**.

Als einer der ältesten und gleichzeitig weltweit bekanntesten Designwettbewerbe werden unter anderem Innovationsgrad, Langlebigkeit sowie funktionale und formale Qualität bewertet.

Das CUBE - Innentürsystem überzeugte die renommierte Jury und erhielt einen **reddot**.

I is a prize winner

Since 1995, Design-Zentrum international has honoured outstanding product design with the coveted **reddot**.

As one of the oldest design competitions, and well-known worldwide, it evaluates the degree of innovation, durability as well as quality in function and form. The CUBE interior door system convinced the high-calibre jury and was awarded a **reddot**.

I a été récompensé

Depuis 1955, le Centre de Design international distingue les designs hors pair en les marquant du célèbre – et très convoité – point rouge : le « **reddot** ».

Ce concours de design est à la fois le plus ancien et le plus célèbre du monde. Les points attribués portent en autres sur le degré d'innovation, la durabilité des produits, ainsi que sur leurs qualités formelles et fonctionnelles.

Le système de portes intérieures CUBE a emporté l'adhésion du jury qui lui a attribué un **reddot**.



reddot design award
winner 2004

CUBE | ist nominiert

Der Designpreis der Bundesrepublik Deutschland ist die einzige offizielle deutsche Designauszeichnung. Der Preis wird vom Bundesminister für Wirtschaft und Arbeit ausgelobt.

Alle nominierten Erzeugnisse müssen bereits eine nationale oder internationale Auszeichnung erhalten haben. Der Designpreis ist somit der Preis der Preise. Nominierung zum Designpreis der Bundesrepublik Deutschland 2006

| is nominated

The German Federal Design Prize is the only official design award in Germany. The prize is sponsored by the Federal Minister for Industry and Employment. All the products nominated must have already won a German or international award. So the Federal Design Prize is the prize of all prizes.

Nominated for the German Federal Design Prize 2006.

| est nominé

Le Prix du Design de la République fédérale d'Allemagne est le seul prix officiel allemand destiné à récompenser le design.

Le Prix a été remis par le Ministre fédéral de l'Économie et du Travail.

Tous les produits nominés doivent déjà avoir obtenu une récompense nationale ou internationale.

Le Prix du Design est donc le Prix des Prix.

Nomination pour le Prix du Design 2006 décerné par la République fédérale d'Allemagne



CUBE | 8





CUBE | Reduktion der Form

Die Flächenbündigkeit von Tür und Zarge, sowie die Option des wandbündigen Einbaus bestimmen die puristische Form. Das auf das Wesentliche reduzierte Zierfutter ist Bestandteil dieser Form. Die Querfurnierung von Tür, Zarge und allen Kanten prägen diese Form. Die Nutzung verdeckter Bandsysteme und der Wegfall der Schlüssellochbohrung unterstreichen diese Form.

PURISTISCH, KUBISTISCH

| Reduction in form

The flush door and frame, as well as the option for flush wall installation, define the purist form. The panelling has been reduced to the essence and is an element of this form.

The cross-veneering of door, frames and all edges characterise this form. The use of concealed flap hinge systems and elimination of the keyhole aperture underline this form.

PURIST, CUBIST

| Épuration de la forme

La juxtaposition des surfaces de la porte et du chambranle, ainsi que le choix délibéré d'un encastrement à fleur de mur, génèrent des formes épurées. Réduits à l'essentiel, les ornements font partie intégrante de la forme.

Le placage transversal de la porte, du chambranle et de tous les éléments latéraux déterminent la forme de la porte. L'utilisation de systèmes de paumelles invisibles et la suppression du perçage du trou de serrure soulignent la forme.

ÉPURÉE, CUBISTE

CUBE | Genial einfach; Einfach Genial
| cleverly simple; simply clever
| d'une géniale simplicité;
| tout simplement génial





CUBE | Innovative Technik; Technische Innovation

- Zweischaliges, kürzbares Zargensystem für den maßgenauen Einbau – chemiefreie Montage möglich
- Feinjustierbares Edelstahlschließblech
- Komfortschloß mit Flüsterfalle und Edelstahlstulp; Schlüsselloch jederzeit nachbohrbar
- Verdeckt liegendes, dreidimensional verstellbares Bandsystem

| innovative technology; technologically innovative

- Double-shell, shortenable frame system for precise installation – chemical-free assembly possible
- Finely adjustable stainless steel strike plate
- Luxury lock with whisper latch bolt and stainless steel faceplate; keyhole can be drilled at any time
- Concealed, three-dimensional flap hinge system

| technologie novatrice; innovation technologique

- Système de chambranle à double paroi, pouvant être raccourci à bonne longueur et autorisant un montage ne faisant pas appel à des produits chimiques
- Gâche en acier inoxydable, autorisant un réglage affiné
- Serrure à pêne silencieux et en acier inoxydable. Le trou de serrure peut faire à chaque instant l'objet d'un nouveau forage
- Système de paumelles invisibles, réglables en 3D









CUBE ELEMENT | Flächenverbund Tür und Zarge
| Flush-fitting door and frame
| Juxta position des surfaces
« porte et chambranle »

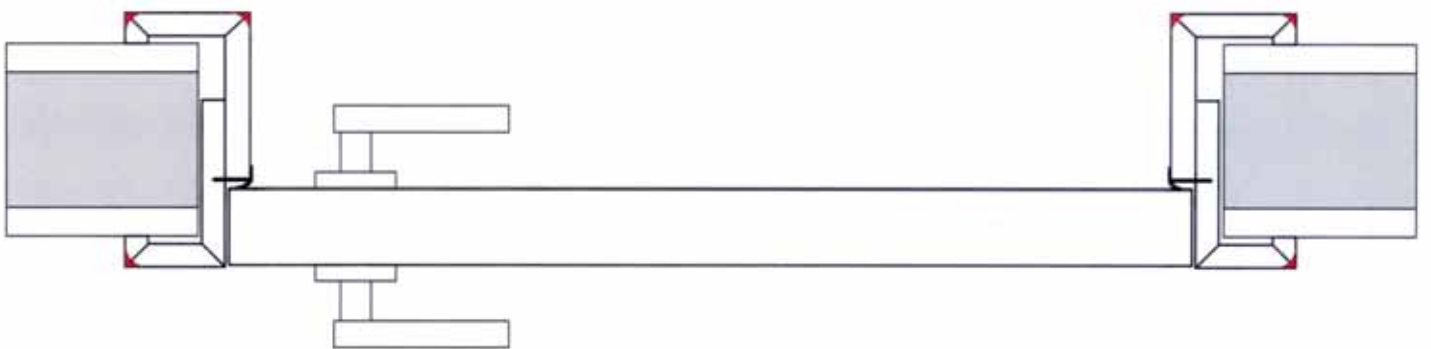

CUBE ELEMENT | Flächenverbund Tür, Zarge und Wand
| Flush-fitting door, frame and wall
| Juxta position des surfaces
« porte, chambranle et mur »





Birke | birch | bouleau

Makassar | ebony | ébène





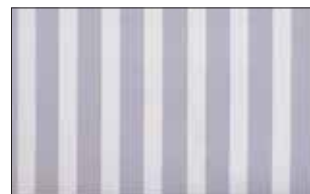

Basic



Opus



Pavé



Uadi



Linea

GLAS | Integraler Bestandteil einer einheitlichen Architektur

- durchgängiges Design
- einheitliche Oberflächen
- aufnahmebereit für handelsübliche Drückergarnituren
- dreidimensional verstellbare Bänder

GLASS | Integral element of a uniform architecture

- consistent design throughout
- uniform surfaces
- ready to hold customary lock fittings
- three-dimensional adjustable flap hinges

Le Verre | fait partie intégrante d'une architecture harmonisée

- Design intégré
- Surfaces harmonisées
- Aptitude à la pose de béquilles couramment vendues dans le commerce
- Paumelles réglables en 3D



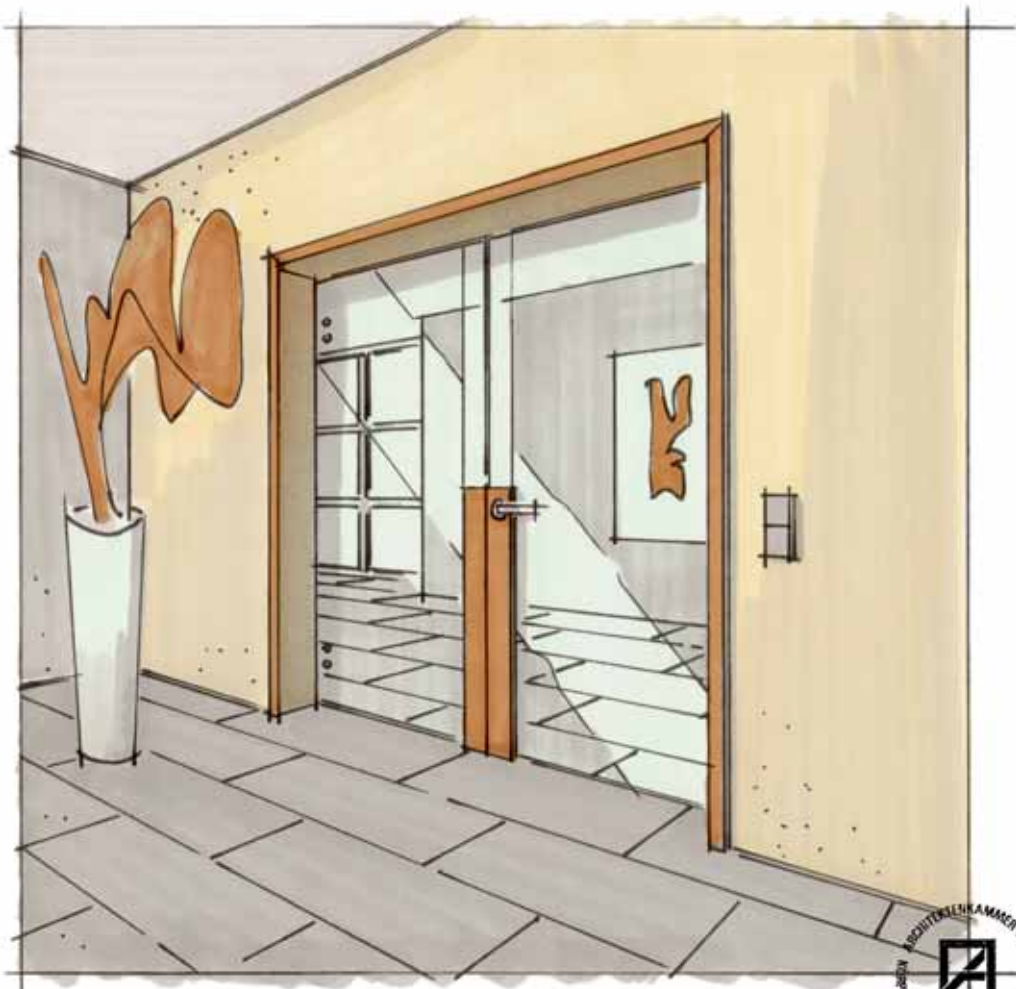





LUMEXX | Verglasung

Flächenbündige Verglasung auf beiden Seiten des Türblattes für höchste Designansprüche. Konsequenter einfach; einfach konsequent.

Gebrauchsmusterschutz:
Deutsches Patent- und Markenamt
Nr. 20 2004 014 179.5

LUMEXX | Glazing

Flush glazing on both sides of door for the highest design aspirations. Consistently simple: simply consistent.

Utility model protection:
German Patent and Trademark Office
No. 20 2004 014 179.5

LUMEXX | Le vitrage LUMEXX

Vitrage très haut de gamme des deux côtés du panneau de porte, satisfaisant aux exigences les plus élevées qui soient en matière de design. Une parfaite simplicité : tout simplement parfaite.

Protection des modèles et dessins :
Office allemand des brevets et des marques
n° 20 2004 014 179.5



LUMEXX | Verglasung

konsequentes Design mit erhöhtem
Schall- und Wärmeschutz

- geometrische Formen
- organische Formen
- frei wählbare Formen

LUMEXX | Glazing

Consistent design with enhanced acoustic and
heat insulation

- geometric forms
- organic forms
- freely selectable forms

LUMEXX | Le vitrage LUMEXX

Design intégré doté de qualités d'isolation
acoustique et calorifique accrues

- Formes géométriques
- Formes organiques
- Formes au choix du client



mexx 110



mexx 111



mexx 370



mexx 440



mexx 610



mexx 630



mexx 640



mexx 641

SCHIEBETÜREN „RÜT“ | Rolle über Tür

SLIDING DOORS “RÜT” | Roller above door

PORTES COULISSANTES « RÜT » | Galet au-dessus de la porte

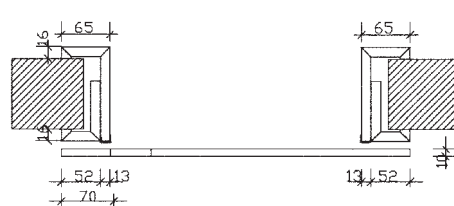
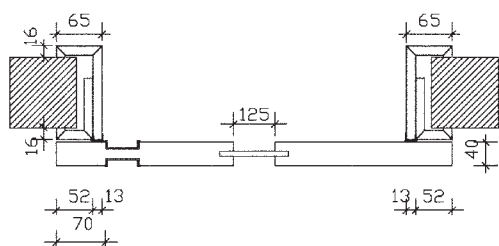
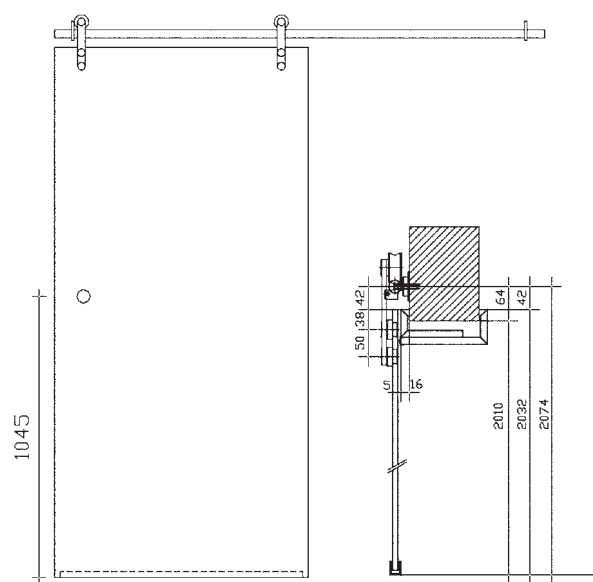
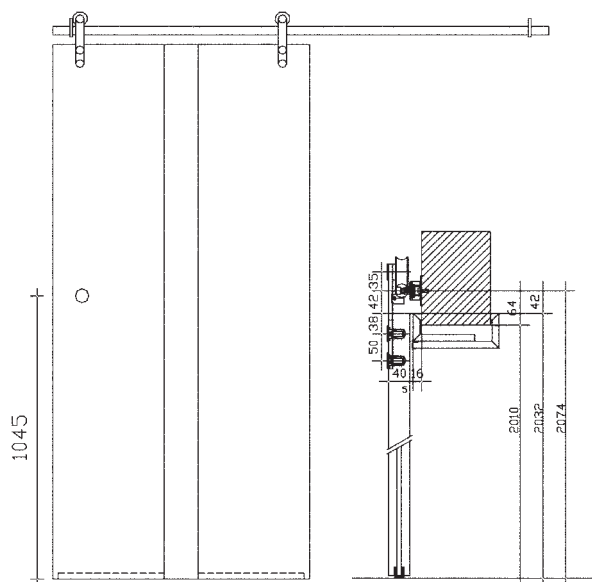



SCHIEBETÜREN „RAT“ | Rolle an Tür
SLIDING DOORS „RAT“ | Roller on door
PORTES COULISSANTES « RAT » | Galet sur la porte

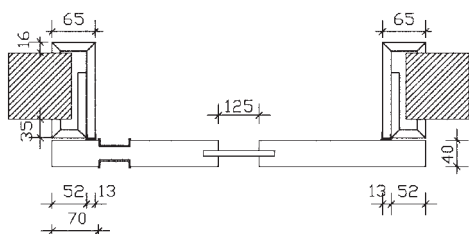
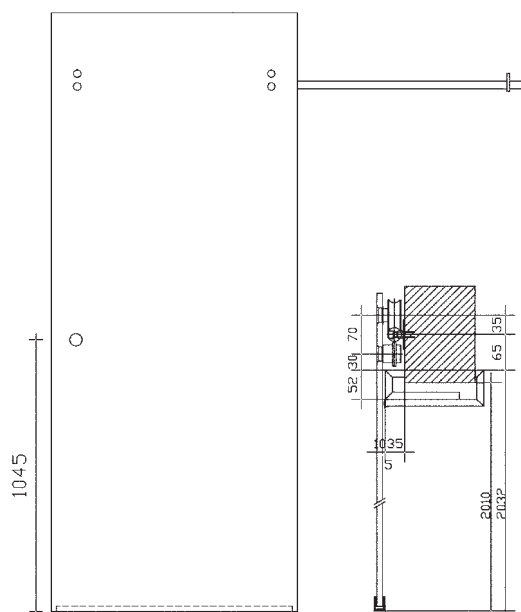
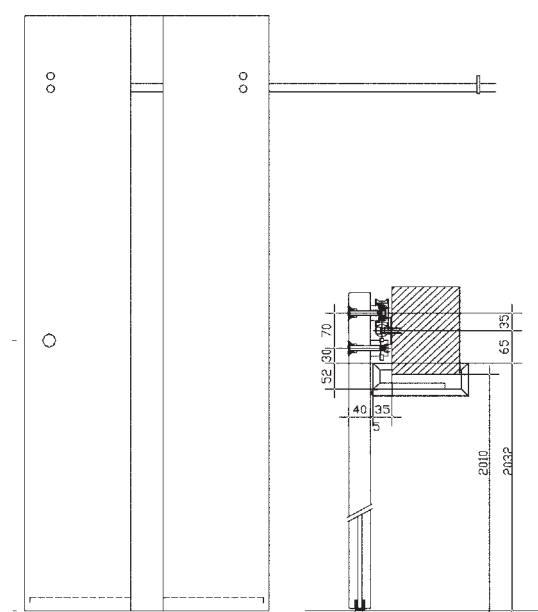





Ein Viertel weniger hoch: halb so schön | One quarter lower: Half as nice | Un quart plus basse : moitié moins belle

Um ein Viertel höher: doppelt so schön | One quarter higher: Twice as nice | Un quart plus haute : deux fois plus belle



STILMITTEL | Türhöhe
| Mid-door height style
| Style « hauteur de porte moyenne »

S

M

L

XL

XXL

XXXL

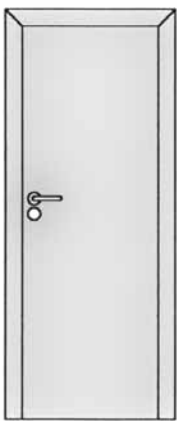

1972

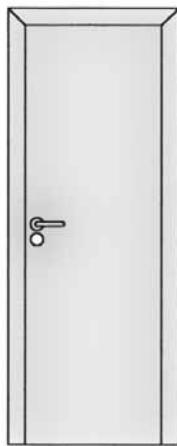

2097

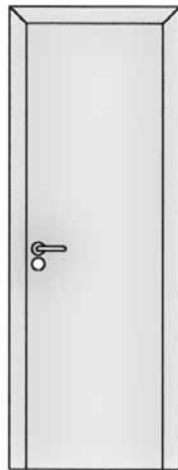

2222

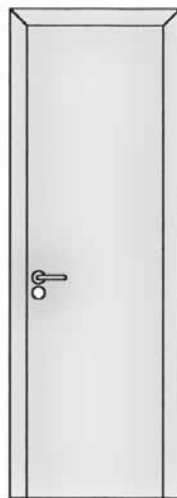

2347

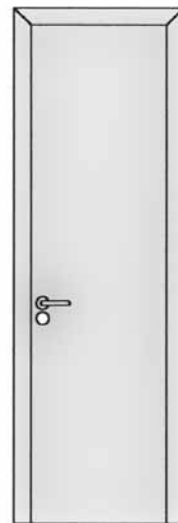

2472



2597
2722
>2722





Birke** | Birch** | Bouleau**



Kalkeiche | Lime oak | Chêne cérusé



Zebrano | Zebrano | Zebrano



Ahorn | Maple | Érable



Kirsch | Cherry | Cerisier

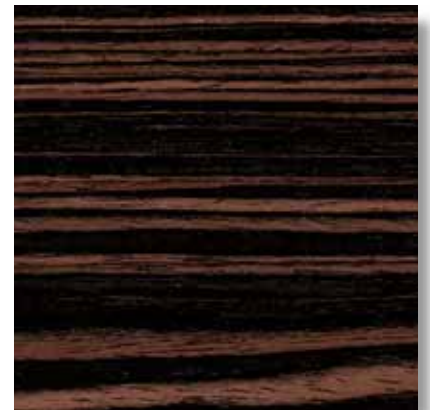

Makassar | Ebony | Ébène



Akatio | Akazio | Acacia



Nuss | Nut | Noyer



Schoko-Eiche | Choko-oak | Chêne chocolat

37 | CUBE

M: 1:2 * Finition-Furniere ** Schäl-Furnier | * Finition veneers ** Rotary-cut veneer | * Placage Finition ** Placage déroulé



Wenge | Wenge | Wengé

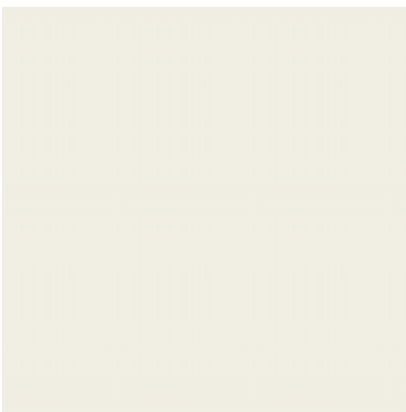

Schleiflack weiß | Eggshell white | Vernis flatting blanc



Schleiflack champagner | Eggshell champagne
| Vernis flatting champagne



Strukturlack grau-silber | Structural lacquer grey-silver
| Vernis à effet gris argent



Strukturlack anthrazit | Structural lacquer
anthracite-silver | Vernis à effet anthracite argenté



Alu-Edelstahl | Alu-steel | Alu-optique inox

FARBSPIEL

Ausgesuchte Streifer* mit mattlackierter Oberfläche werden auf Türen und Zargen querfurniert. Hochwertige Schleif- und Strukturlacke sind in Standard- und Sonderfarbtönen lieferbar. Vielfache Kombinationsmöglichkeiten unterschiedlicher Hölzer und/oder Lackoberflächen schaffen gestalterischen Raum für mehr Individualität.

COLOURPLAY

Selected stripers* with matt lacquered surfaces are cross-veneered on doors and frames. High-quality eggshell and structure lacquers are available in standard and special colour tones. Numerous options to combine different wood and/or lacquered surfaces offer creative space for more individuality.

LE JEU DES COULEURS

Les revêtements rayés haut de gamme* à surface laquée de peinture mate sont appliqués sur les portes et chambranles sous forme de placage transversal. Les vernis flatting et les vernis à effet haut de gamme sont disponibles standard ou en coloris spéciaux. La grande variété d'essences de bois et/ou de surfaces peintes offre de multiples possibilités d'association, créant et rythmant un espace ciblé sur une personnalisation accrue.

N° 0030 Alu

N° 0031 Edelstahl

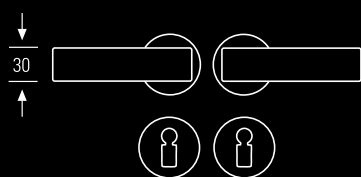
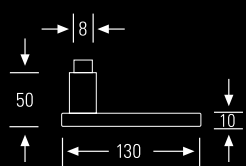

| 55 |

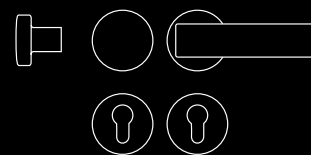
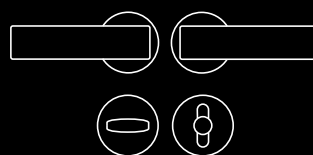

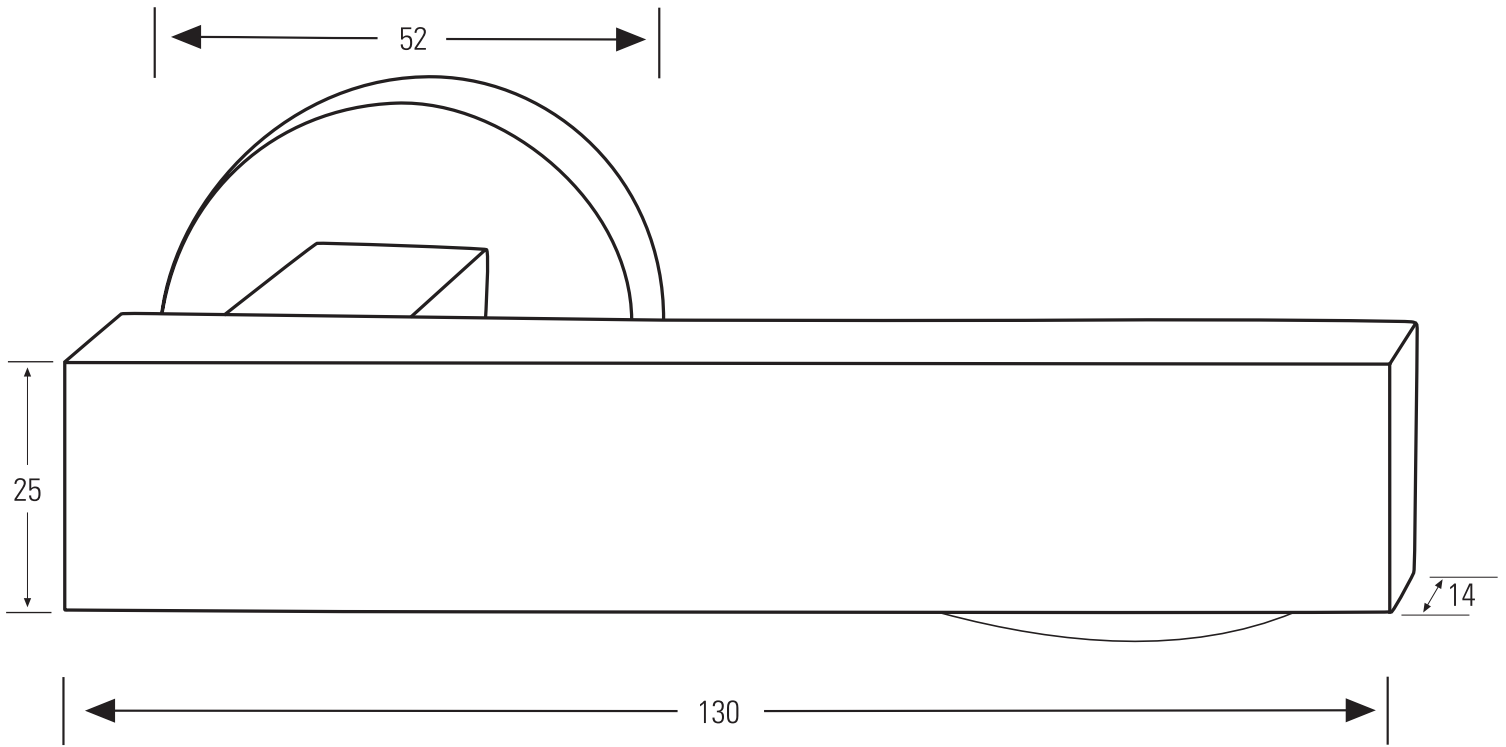

Nº 0040 Alu

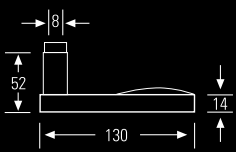

| 52 |



| 41 |



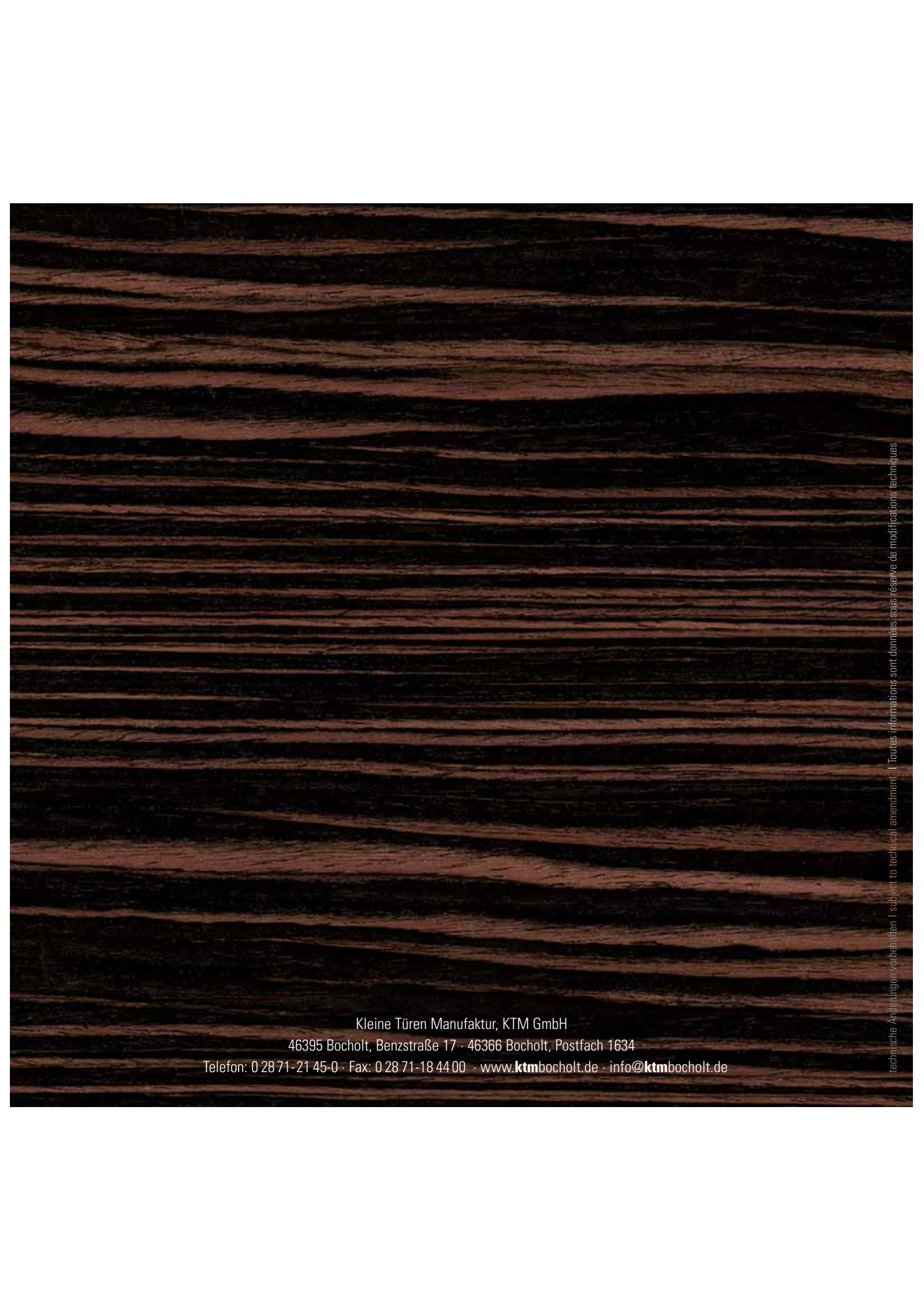

Kleine Türen Manufaktur, KTM GmbH
46395 Bocholt, Benzstraße 17 · 46366 Bocholt, Postfach 1634
Telefon: 0 28 71-21 45-0 · Fax: 0 28 71-18 44 00 · www.ktmbocholt.de · info@ktmbocholt.de